

Installation manual “installing (optional) bottom light afterwards”



**20901583 (e-MatriX linear)
20901626 (e-MatriX mood)
20901629 (e-MatriX 800/1600 ST)**

40012178-2302





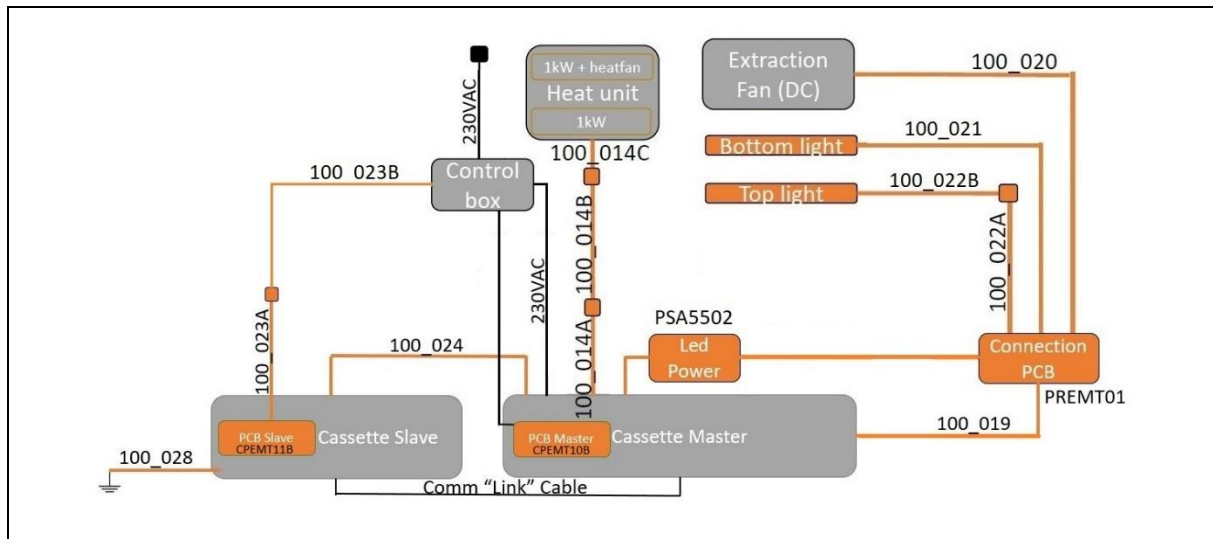

Wiring diagram e-Matrix linear-serie

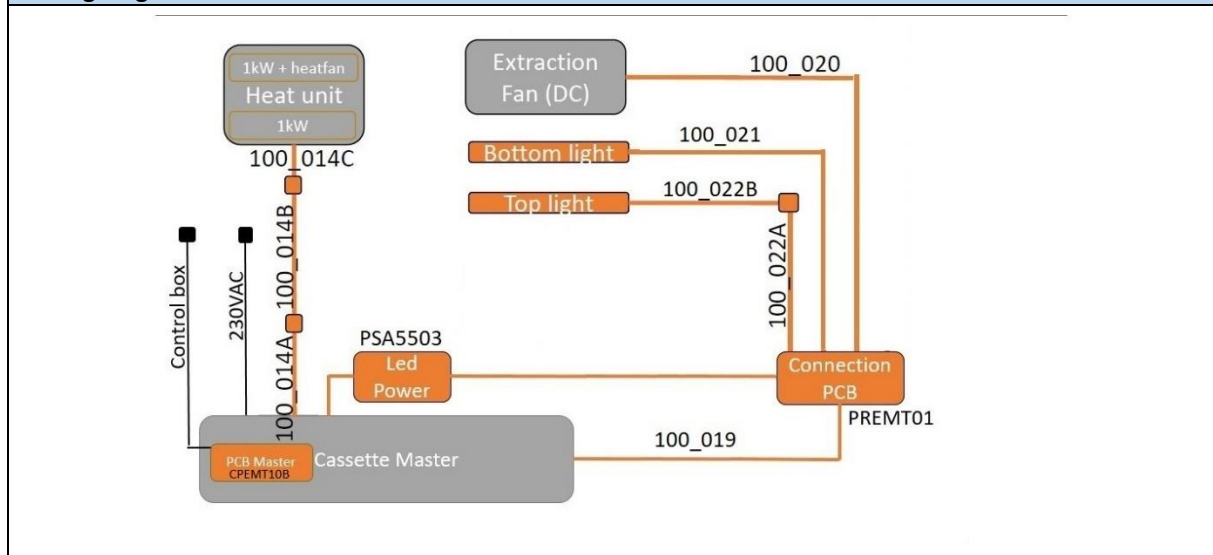

Wiring diagram e-Matrix mood-serie

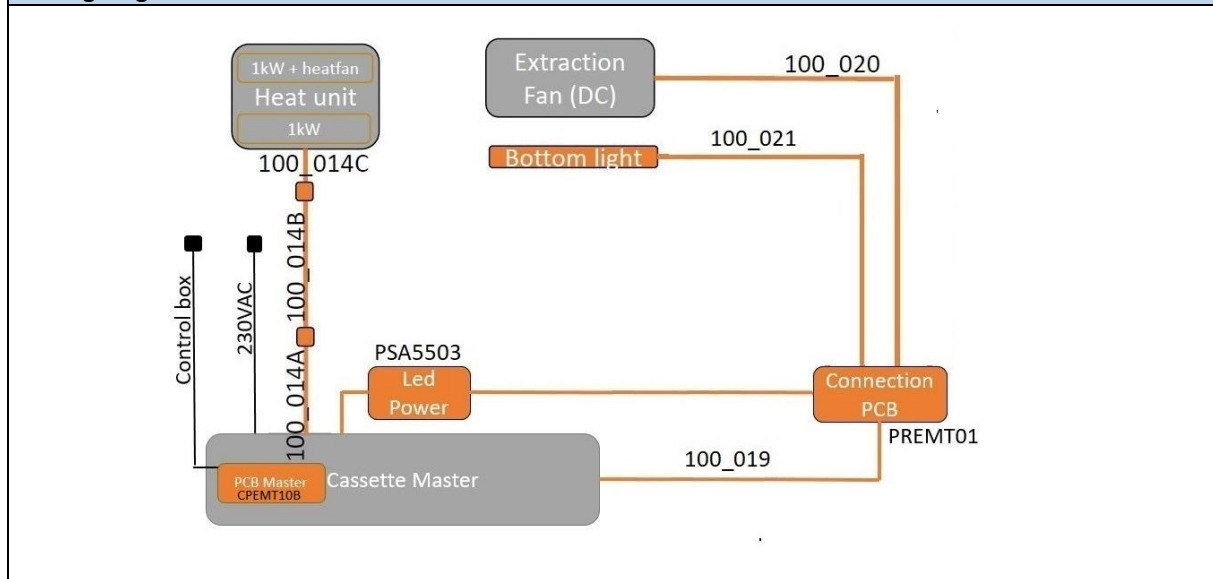

Wiring diagram e-Matrix 800/1600 ST



Remove the decoration set and the existing bottom plate without LED.



Let the LED bottom plate rest carefully at the front of the fire.

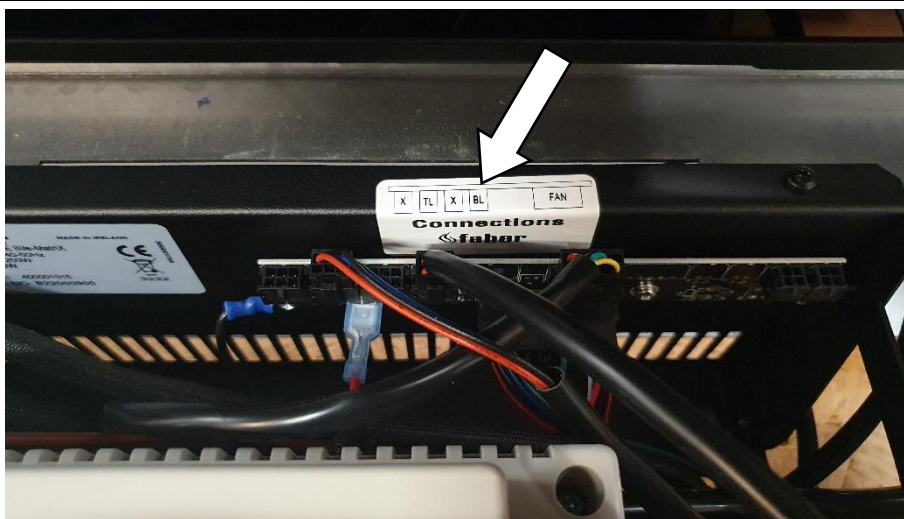
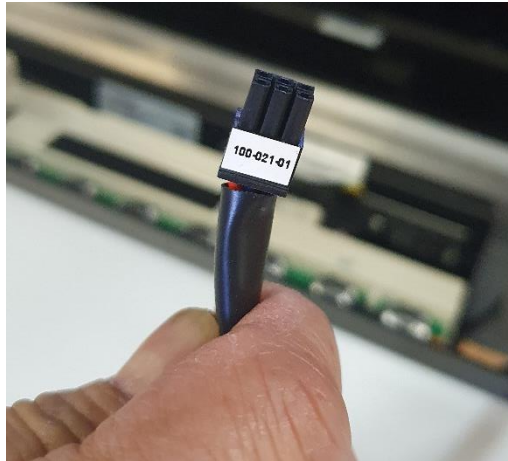

Insert the connection cable into the "BL" connector of the terminal block.



Carefully place the bottom plate. (Check that the cable will not block the outflow opening (fire opening) of the Engine).



Attention! If top lighting is going to be installed also in addition to bottom lighting or top lighting is installed already, first in the settings of the App activate the bottom lighting and (fireplace) type and then (de)activate the top lighting!

Once the bottom light is connected, in the App settings you need to make it known that bottom lighting is connected and for which (fireplace) type that is (Make sure you are connected to the fireplace with the App):







www.faberfires.com

Saturnus 8

Postbus 219

contact@faberfires.com

NL 8448 CC Heerenveen

NL 8440 AE Heerenveen